

from Na_3Pb_4 to Na_5Pb_2 . However, there were no temperature halts corresponding to the 190° halt in this region during cooling or heating.

Solid Solubility.—According to previous knowledge, Na_5Pb_2 dissolves both sodium and lead, and

NaPb dissolves sodium. The present thermal data show no appreciable solid solubility for either compound. Also, little solid solubility is indicated for the Na_3Pb_4 region.

DETROIT, MICHIGAN

[CONTRIBUTION FROM THE LOS ALAMOS SCIENTIFIC LABORATORY, UNIVERSITY OF CALIFORNIA]

The Partial Phase Diagram of the System CaI_2 - CaF_2 ¹

BY WILLIAM J. MCCREARY

RECEIVED NOVEMBER 15, 1954

The phase diagram of the system CaI_2 - CaF_2 is a simple binary eutectic up to 53 mole % CaF_2 . CaI_2 was purified by vacuum distillation. The f.p. of CaI_2 is $783.7 \pm 1.0^\circ$, CaF_2 freezes at $1414 \pm 5^\circ$, and the eutectic composition of 17.5 mole % CaF_2 freezes at $667.9 \pm 2^\circ$.

Introduction

In 1903 Ruff and Plato² published a paper which contained a partial phase diagram for the system CaI_2 - CaF_2 . This diagram agrees with the present work only in the composition of the eutectic mixture. The difficulty in obtaining accurate data on this system is due primarily to the nature of the CaI_2 . This salt is very hygroscopic and decomposes readily when heated in air or when heated in any atmosphere when the salt contains moisture. Complete dehydration can be effected by fusing in an inert atmosphere, but the resulting salt is contaminated with CaO .

Furthermore, at the relatively high temperatures required to melt mixtures rich in CaF_2 , the vapor pressure of CaI_2 is sufficiently high to appreciably change the composition of the mixture. This is especially serious when using very small samples necessary for microscopic observation, one of the techniques in the present work.

Ceramic crucibles, such as MgO and CaO , were readily dissolved by the melt at high temperatures, and platinum crucibles deteriorated rapidly. Bare platinum-platinum 10% rhodium thermocouples also dissolved in the melt at high temperatures. Tantalum and graphite appeared to be the least affected of any of the materials used.

Experimental

Preparation of Materials.—Reagent grade CaF_2 (J. T. Baker) was considered to be of sufficient purity for this study and was used as received. Spectrochemical analysis indicated the salt was better than 99.1% pure and an X-ray pattern showed no impurities.

Calcium iodide is a deliquescent salt which is unstable except in a dry, inert atmosphere. The hydrated salt can be prepared, in pure form, by treating CaCO_3 with HI .³ However, attempts to remove H_2O by heating *in vacuo* followed by fusion, or fusing the salt mixed with NH_4I or in an atmosphere of HI ^{3,4} resulted in partial decomposition of the salt.

Wolsky, *et al.*,⁵ prepared CaI_2 of $99.5 \pm 0.5\%$ purity by adding $\text{Ca}(\text{NO}_3)_2$ and NH_4I to liquid NH_3 . The precipitate

of $\text{CaI}_2 \cdot 8\text{NH}_3$ was recrystallized and the NH_3 removed by heating slowly to 190° *in vacuo*.

For this work, CaI_2 was prepared by vacuum distillation. Finely ground reagent grade $\text{CaI}_2 \cdot x\text{H}_2\text{O}$ was partially dehydrated by slowly heating the salt to 120° *in vacuo*. The H_2O was trapped with either P_2O_5 or $\text{Mg}(\text{ClO}_4)_2$. The dried salt was then distilled from a platinum crucible in a quartz tube at approximately 820° , the cooler upper walls of tube serving as the condenser. Pressure of the system during distillation was approximately 0.02μ . The CaI_2 was always handled in an atmosphere of dry helium or argon.

Spectrochemical analysis of the distilled salt indicated less than 166 p.p.m. total cation impurities. Calcium was determined by precipitation of the oxalate from acid solution. The precipitate was ignited at 500° and weighed as CaCO_3 . Iodine was precipitated and weighed as AgI . Results are: theoretical: Ca, 13.64; I, 86.36. Found: Ca, 13.70 ± 0.06 (all deviations are standard = $\sqrt{\Sigma d/n - 1}$); I, 86.11 ± 0.43 .

Experimental Techniques.—Three methods were employed to detect temperatures at which phase changes occurred. The f.p. of pure CaI_2 , pure CaF_2 and the eutectic mixture were determined by conventional cooling curves, wherein a plateau on a time-temperature plot indicated a phase change. This method was not sufficiently sensitive to detect formation of pure crystals in a molten mixture.

Saturation temperatures on mixtures containing not more than 20 mole % CaF_2 were obtained from an inverse-rate plot. In this method the time required for the sample to cool a fixed amount is plotted *versus* temperature, the phase change being indicated by a sudden increase in time.

The salts were contained in either platinum or tantalum crucibles, except that a graphite crucible was used for pure CaF_2 . The average sample weight was about 5 g. The crucible was placed in a quartz tube which was closed with a ground-jointed cap through which a platinum- or tantalum-tipped stainless steel tube was passed. This tube served as a thermocouple well and could be moved vertically for stirring the sample. The gland through which the tube passed consisted of a Pyrex tube which was sealed to the cap and was fitted with surgical rubber tubing whose normal inside diameter was less than the diameter of the steel tube. When the rubber was lubricated with vacuum grease, the steel tube could be moved without changing the pressure in the system.

The furnace was essentially as described by Kracek.⁶ The temperature was controlled by a Wheelco Potentiometer and the heating or cooling rate could be adjusted to about 2° per minute. All runs were made in an atmosphere of dry argon after outgassing the system by slow heating to 200° *in vacuo*.

It was not possible to obtain saturation temperatures on mixtures containing more than 20 mole % CaF_2 by either of the foregoing methods. On cooling, the melts appeared not to undergo a phase change until the eutectic was reached. The reason for this is not known, unless the heat effect accompanying the formation of pure solid was too small to register.

(1) Work done under the auspices of the Atomic Energy Commission.

(2) W. Plato and O. Ruff, *Ber.*, **36**, 2357 (1903).

(3) G. P. Baxter and F. N. Brink, *THIS JOURNAL*, **30**, 46 (1908).

(4) J. W. Mellor, "A Comprehensive Treatise on Inorganic Chemistry," Vol. III, Longmans, Green and Co., New York, N. Y., 1952, p. 734.

(5) S. P. Wolsky, E. J. Zdanuk and L. V. Coulter, *THIS JOURNAL*, **74**, 6196 (1952).

(6) F. C. Kracek, *J. Phys. Chem.*, **33**, 1287 (1929).

Most of the data on this system were obtained by observing the sample with the aid of a stereoscopic microscope and recording the temperature at which crystals were seen to form or disappear. The micro furnace is shown in Fig. 1. The three concentric cylinders shown in the sketch contained the heating element and thermocouple. The platinum heating wire (26BS gage) was wound in external grooves on the inner cylinder. The thermocouple was wound in twin lead grooves on the middle cylinder, which allowed about one foot of the thermocouple to lie in the hot part of the furnace, thus eliminating heat leak from the junction. The outer cylinder held the thermocouple in place. The heater wire and thermocouple wire led out of the furnace through Kovar-Glass seals. Two variacs in series with a constant voltage regulator were used to control the temperature of the furnace.

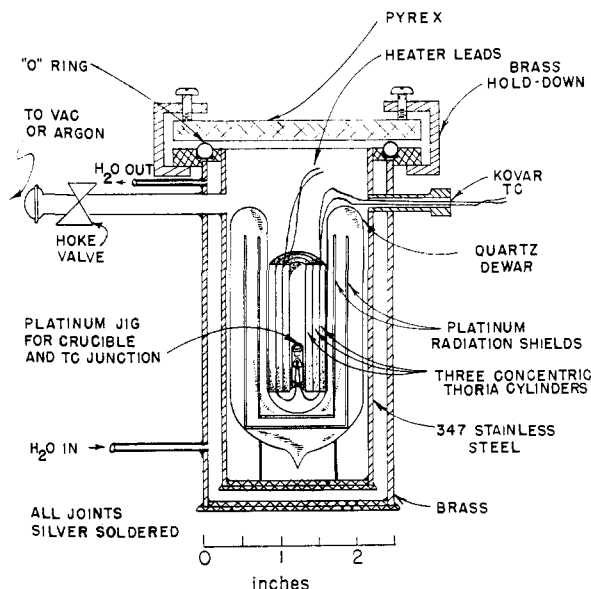

Fig. 1.—Micro furnace.

The principal advantages of this furnace are rapid heating and cooling (maximum temperature about 1400°) and close control of the temperature. Temperature gradients are small because of the favorable diameter to length ratio. Since incident lighting is used, metal crucibles can be used, thus avoiding reactions between container and sample.⁷ The quartz dewar and thoria cylinders are easily outgassed, and contamination of the sample from this source is eliminated. (If contamination is not a factor, lavite cylinders are easier to machine and are quite satisfactory.)

The principal disadvantage is the difficulty encountered in illuminating the sample. In this work an Erb and Gray microscope illuminator was satisfactory. However, above 1100° radiation from the furnace is brighter than the illumination from the light source, and detail in the sample is lost. The use of filters and some other light source might make the sample visible above this temperature.

Average sample weight was 10 mg. After loading the furnace in a dry-box, the apparatus was outgassed by slowly heating to about 200° *in vacuo*. The apparatus was then flooded with argon and maintained at 1 atm. throughout the run. The sample was heated until all solids had dissolved and then slowly cooled until crystals formed. The first appearance of a crystal was easily detected using 36X magnification. After a few crystals had formed the sample was slowly heated until the last trace of solid disappeared. The temperature at which this occurred was taken as the saturation temperature. Convection currents in the sample provided ample mixing of the salts.

Temperatures were measured with platinum-platinum 10% rhodium thermocouples which were calibrated by comparing with a couple that had been checked and certified

(7) C. P. Saylor, in "Temperature, Its Measurement and Control in Science and Industry," Reinhold Publ. Corp., New York, N. Y., 1941, pp. 677-679.

by the National Bureau of Standards. In the case of regular cooling curves, the e.m.f. *vs.* time was recorded on a 3-range Brown millivolt recorder, which was further calibrated by determining the f.p. of standard metals. Frequent checks on the recorder were made by taking simultaneous readings with a Rubicon type B potentiometer. Accuracy up to the f.p. of copper was about 0.5°.

The thermocouple in the micro-furnace was of platinum-platinum 10% rhodium calibrated as above. The e.m.f. was measured with the Rubicon potentiometer. The system was calibrated by determining the f.p. of NaCl (801°). Accuracy at this temperature was 0.5°.

Results

Data are shown in form of a phase diagram in Fig. 2. The f.p. of pure CaI_2 was found to be $783.7 \pm 1.0^\circ$. Calcium fluoride was found to freeze at $1414 \pm 5^\circ$, in good agreement with Naylor's value of 1418° .⁸ The eutectic mixture contains 17.5 mole % CaF_2 and freezes at $667.9 \pm 2^\circ$.

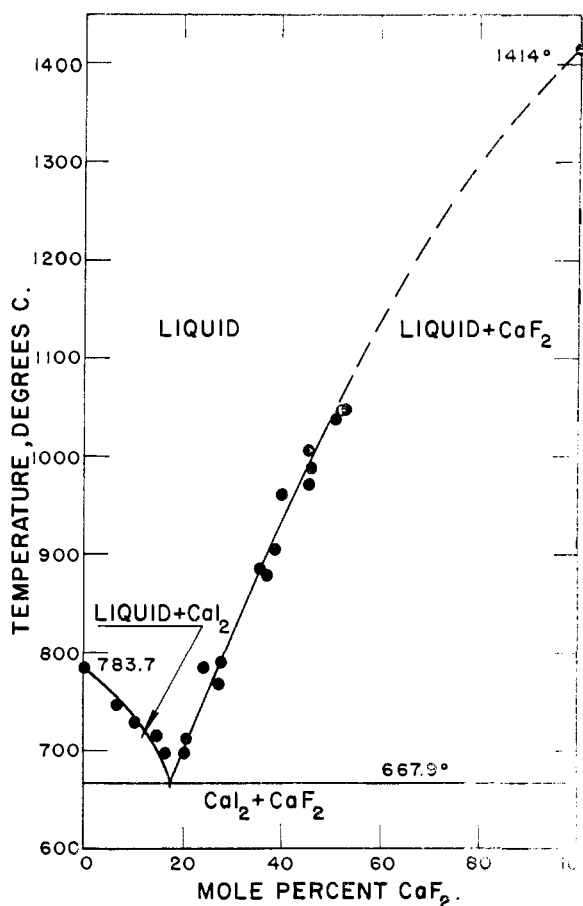

Fig. 2.

Over the range of compositions for which saturation temperatures were obtained, the phase diagram is that of a simple binary eutectic. With the techniques used in this investigation it was impossible to obtain saturation temperatures on mixtures containing more than 53 mole % CaF_2 . This was primarily due to the rapid evaporation of CaI_2 (and to a lesser extent, CaF_2) at higher temperatures.

LOS ALAMOS, N. M.

(8) B. F. Naylor, *THIS JOURNAL*, **67**, 150 (1945).